

轻巧化 智能 自动 生产线  
Lightening Smart Auto Production line

成型 裁断 堆叠 包装 一次到位  
Forming Cutting Stacking Packaging Once for all



微信二维码



WhatsApp

## Contact us

### 联系我们

- ☎ 0086 13802336664
- ✉ [rm@rm-machine.cn](mailto:rm@rm-machine.cn) / [rm-a@rm-machine.cn](mailto:rm-a@rm-machine.cn)
- 📍 汕头市金平区月华工业区3横10号  
One Of No.10, 3h, East Side Of Yuehua Industrial Zone, Shantou, Guangdong, China



路百拓

RM-SERIES  
HIGH SPEED

THERMOFORMING MACHINE  
RM-系列高速压空成型机

FORMING → PACKAGING

汕头市路百拓机械有限公司  
汕头市路博恩机械有限公司  
SHANTOU RAYBURN MACHINERY CO., LTD

# Company Profile 公司简介

Shantou Rayburn Machinery Co., Ltd was founded in 2019, which is a research and development enterprise specializing in the design and manufacture of various types of plastic machinery and professional customization of molds. Now we have a professional management, design and development, production team, which is committed to providing customers with disposable plastic products machinery production line solutions, and it has become a brand machinery manufacturer with excellent products and services to win the recognition of customers and society.

Our company's leading products are RM series high-speed multi-station positive and negative pressure thermoforming machines and RM series large format four-station thermoforming machine, which are applying to disposable plastic equipment. All kinds of plastic products mold design and development of automatic auxiliary equipment in the production line are available. Our equipments have been sold well in the domestic and foreign market for many years and have a good reputation.

汕头市路百拓机械有限公司创建于2019年,是一家专业从事各类塑料机械设计制造、模具专业定制的研发型企业。公司现拥有一支专业的管理、设计研发、生产团队,致力于为客户提供一次性塑料用品机械生产线的解决方案,已然成为一家品牌机械制造厂家,以优秀的产品和服务赢得了客户和社会的认可。

公司的主导产品为RM系列高速多工位正负压热成型机, RM1011大版面四工位正负压热成型机等一次性塑料用品设备、各类塑料制品模具设计开发生产线中的自动化辅助设备,设备畅销国内外市场,口碑优良。



## contents 目录



- 01-02** RM-T1011+GC-7+GK-7 High Speed Thermoforming Production Line  
RM-T1011 连续式压空成型生产线
- 03-04** RM-2RH Double-station IMC Thermoforming Machine  
RM-2RH 双工位模内切正负压热成型机
- 05-06** RM-2R Double-station IMC Thermoforming Machine  
RM-2R 双工位模内切正负压热成型机
- 07-08** RM-3 Three-station Thermoforming Machine  
RM-3 三工位正负压热成型机
- 09-10** RM-4 Four-station Thermoforming Machine  
RM-4 四工位正负压热成型机

# RM-T1011

## RM-T1011 + GC-7 + GK-7 High Speed Thermoforming Production Line

(Forming→Punching→Cutting+Stacking)

连续式压空成型生产线 (成型→冲孔→冲边+码垛)

### Function diagram/功能示意



Forming  
压空成型



Punching  
中央打孔



Cutting  
外形截断



Stacking  
自动堆叠

### Scope of application/适用范围

Bowl/ Box/ Lid/ Flower pot/  
Fruit box/ Tray etc.

碗、盒、盖、花盆、水果盒、托盘等

### Machine parameters/机器参数

Max. Mould Dimensions	Clamping Force	Punching Capacity	Cutting Capacity	Max. Forming Height	Max. Air Pressure	Dry Cycle Speed	Max. Punching/Cutting Dimensions	Max. Punching/Cutting Speed	Suitable Material
成型面积	锁模力	冲孔力	冲切力	成型高度	成型压力	成型运转速度	冲孔/冲切面积(mm)	冲孔/冲切速度	材料
1000*1100mm	50T	7T	7T	150mm	6 Bar	35 r/min	1000*320	100 spm	PP、HIPS、PET、PS、PLA



质量为先·服务之上

01-02

# RM-2RH

## RM-2RH Double-Station In-mould Cutting Thermoforming Machine

[Hardware steel knife cutting and on-line stacking]

双工位模内切正负压热成型机

【配备模内五金刀模裁切+在线码垛】

### Machine parameters/机器参数

Max. Mould Dimensions	Clamping Force	Dry Cycle Speed	Max. Sheet Thickness	Max. Forming Height	Max. Air Pressure	Suitable Material
成型面积	锁模力	运转速度	片材厚度	成型高度	成型压力	材料
820x620mm	85T	48/cycle	2.8mm	180mm	8 Bar	PP, PS, PET, CPET, OPS, PLA

### Function diagram/功能示意



Forming  
压空成型

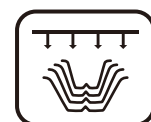

Stacking  
自动堆叠

### Range of Application/适用范围

Suitable for large height products such as cold drink cup/container/bowl etc.

冷饮杯、盒、碗等大高度的产品



质量为先 · 服务之上

03-04

# RM-2R

## RM-2R Double-station In-mould Cutting Thermoforming Machine

[Hardware steel knife or steel rule cutting and on-line stacking]

双工位模内切正负压热成型机

【配备模内五金刀模裁切+在线码垛】

Function diagram/功能示意



Forming  
压空成型



Stacking  
自动堆叠

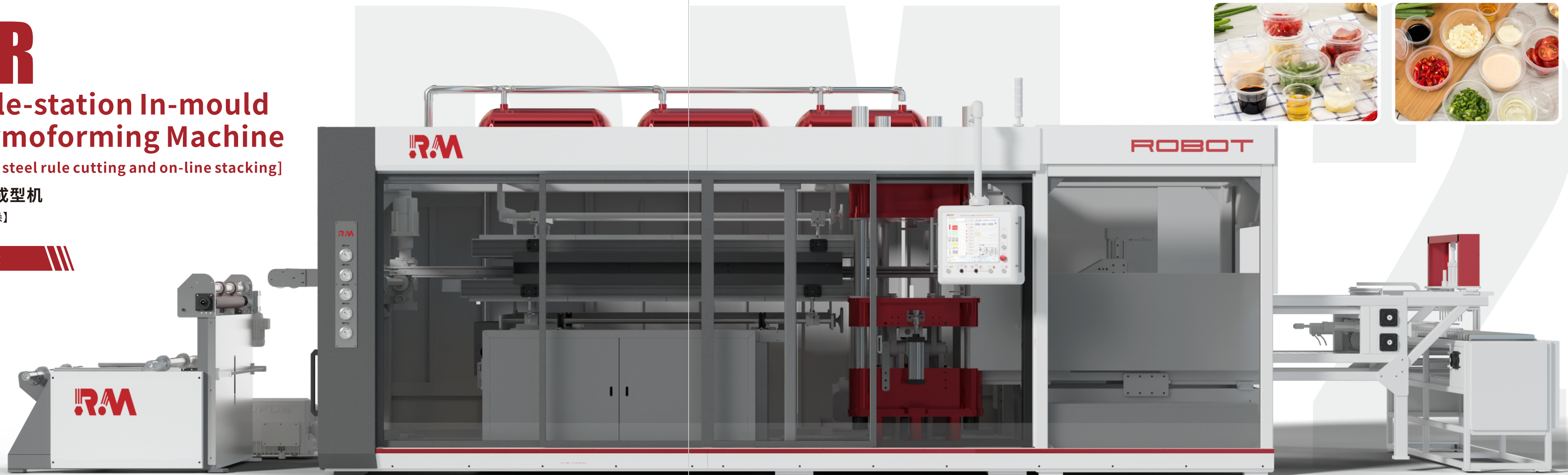

Scope of application/ 适用范围

Suitable for sauces cup/plate/lid and other small height products.

酱料杯、盘、盖等小高度的产品

Machine parameters/机器参数

Max. Mould Dimensions	Clamping Force	Dry Cycle Speed	Max. Sheet Thickness	Max. Forming Height	Max. Air Pressure	Suitable Material
成型面积	锁模力	运转速度	片材厚度	成型高度	成型压力	材料
820x620mm	65T	48/cycle	2.0mm	80mm	8 Bar	PP, PS, PET, CPET, OPS, PLA

质量为先·服务之上

# 05-06

# RM-3

## RM-3 Three-station Thermoforming Machine

[Forming - Cutting - Stacking]

三工位正负压热成型机【成型-裁切-码垛】

Function diagram/功能示意



Forming  
压空成型



Cutting  
外形裁断



Stacking  
自动堆叠

Machine parameters/机器参数

Max. Mould Dimensions	Clamping Force	Dry Cycle Speed	Max. Sheet Thickness	Max. Forming Height	Max. Air Pressure	Suitable Material
成型面积	锁模力	运转速度	片材厚度	成型高度	成型压力	材料
820x620mm	80T	61/cycle	1.5mm	100mm	6 Bar	PP, PS, PET, CPET, OPS, PLA

Scope of application/适用范围

Suitable for tray/ lid/ lunch box/ folding box etc.

托盘、盖、餐盒、连体盒等产品

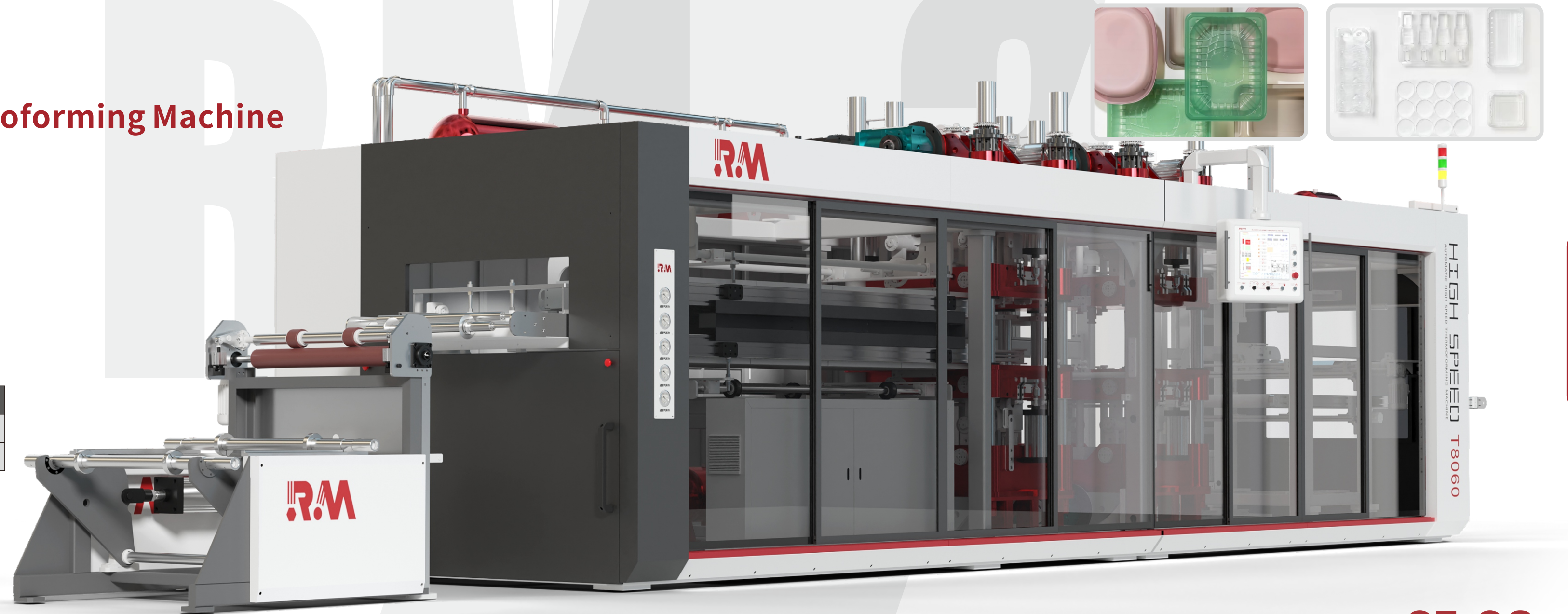

质量为先 · 服务之上

07-08

# RM-4

## RM-4 Four Station Thermoforming Machine

[Forming - Punching - Cutting - Stacking]

四工位正负压热成型机【成型-冲孔-裁切-码垛】

### Scope of application/ 适用范围

Suitable for punching hole products such as flowerpot/fruit box/coffee lid/dome lid etc.

花盆、水果盒、咖啡杯盖、球盖等  
需要冲孔的产品

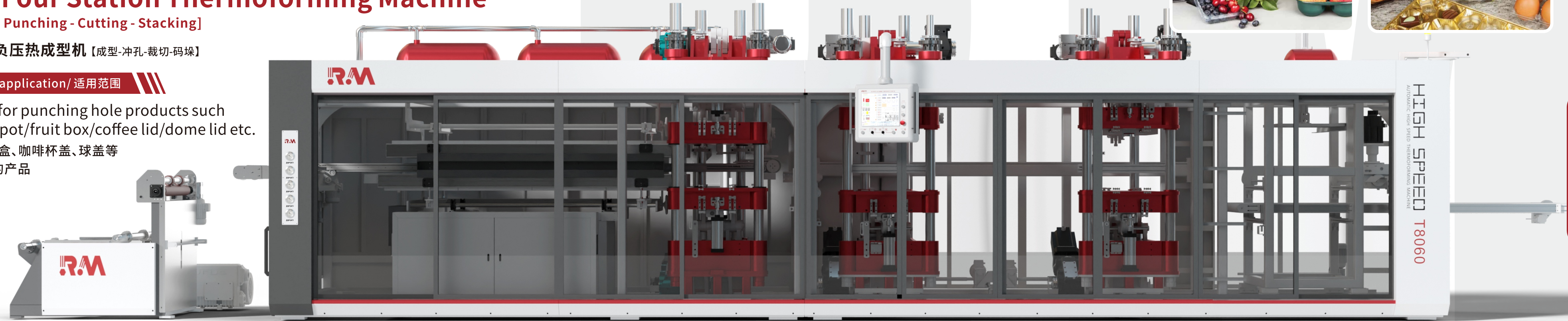

### Machine parameters/ 机器参数

Max. Mould Dimensions	Clamping Force	Dry Cycle Speed	Max. Sheet Thickness	Max. Forming Height	Max. Air Pressure	Suitable Material
成型面积	锁模力	运转速度	片材厚度	成型高度	成型压力	材料
820x620mm	80T	61/cycle	1.5mm	100mm	6 Bar	PP, PS, PET, CPET, OPS, PLA

### Function diagram/ 功能示意



Forming  
压空成型



Punching  
中央打孔



Cutting  
外形截断



Stacking  
自动堆叠

质量为先 · 服务之上

# 09-10

# RM-2RH

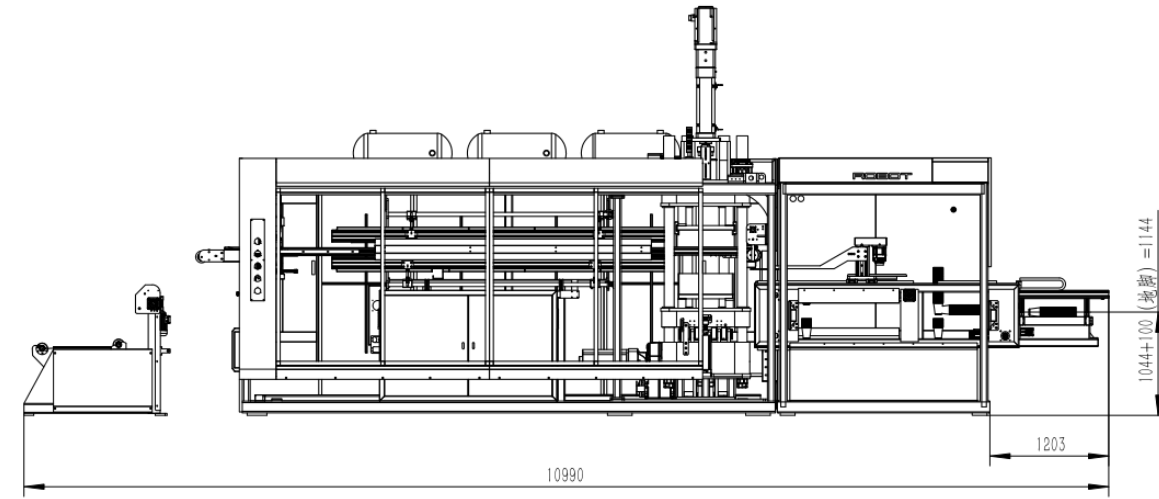

# RM-2R

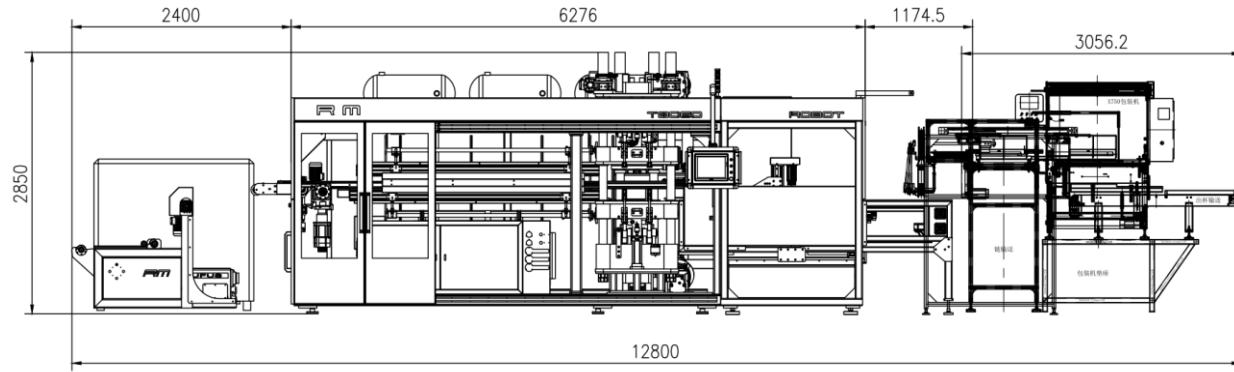

# RM-2

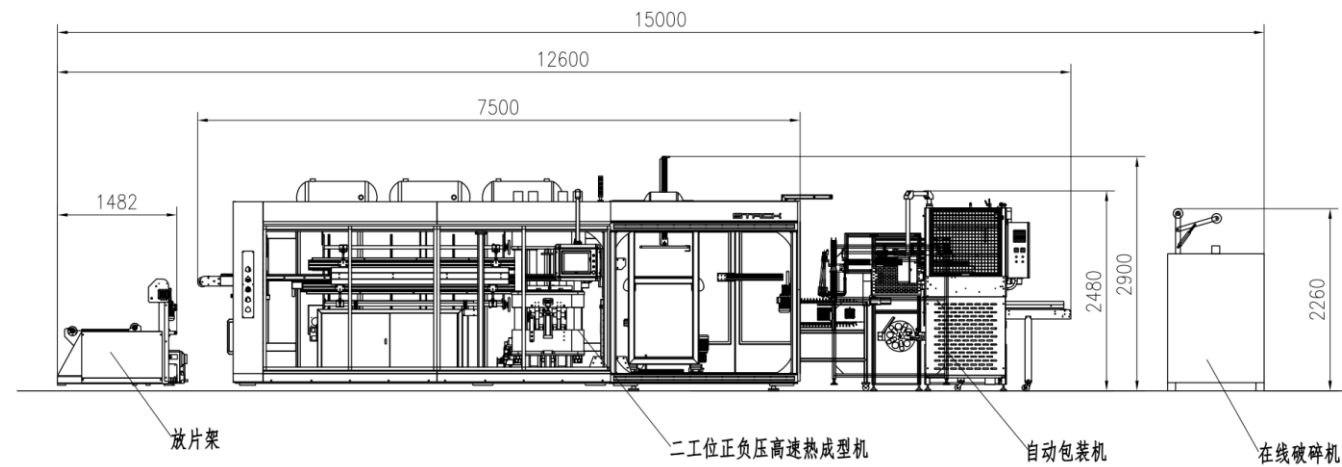

# RM-3

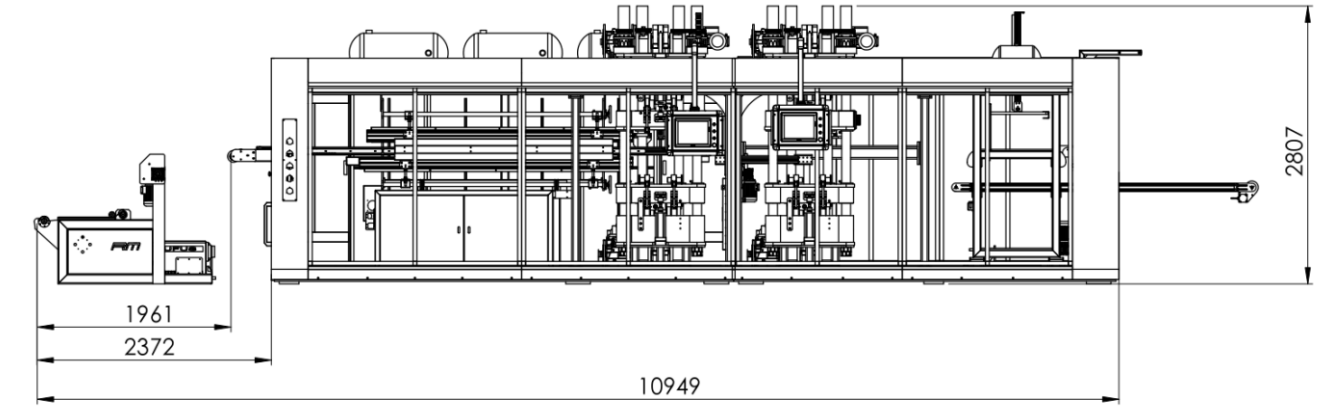

# RM-4

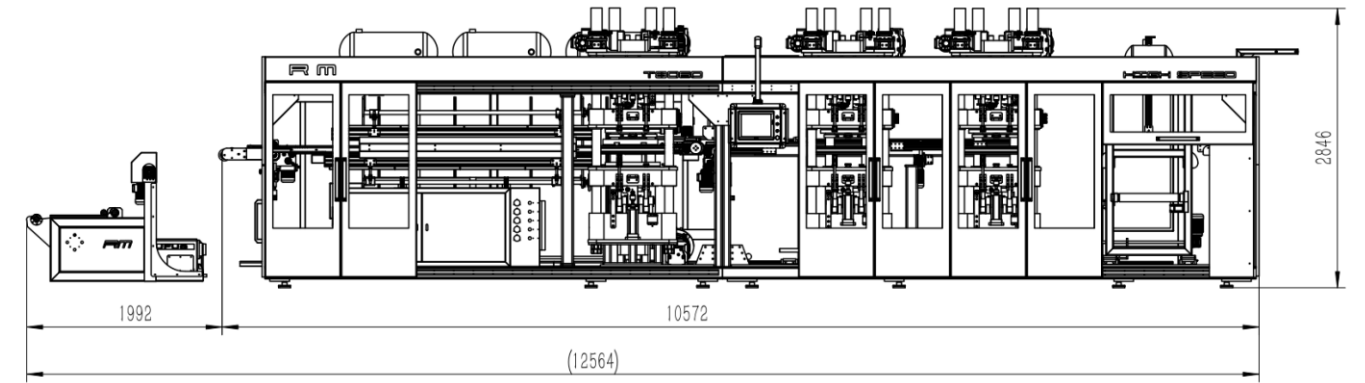

# RM-T1011

